

TS-100 Drilling Machine

The most versatile light weight and compact hydraulic feed drilling machine with improved advantages

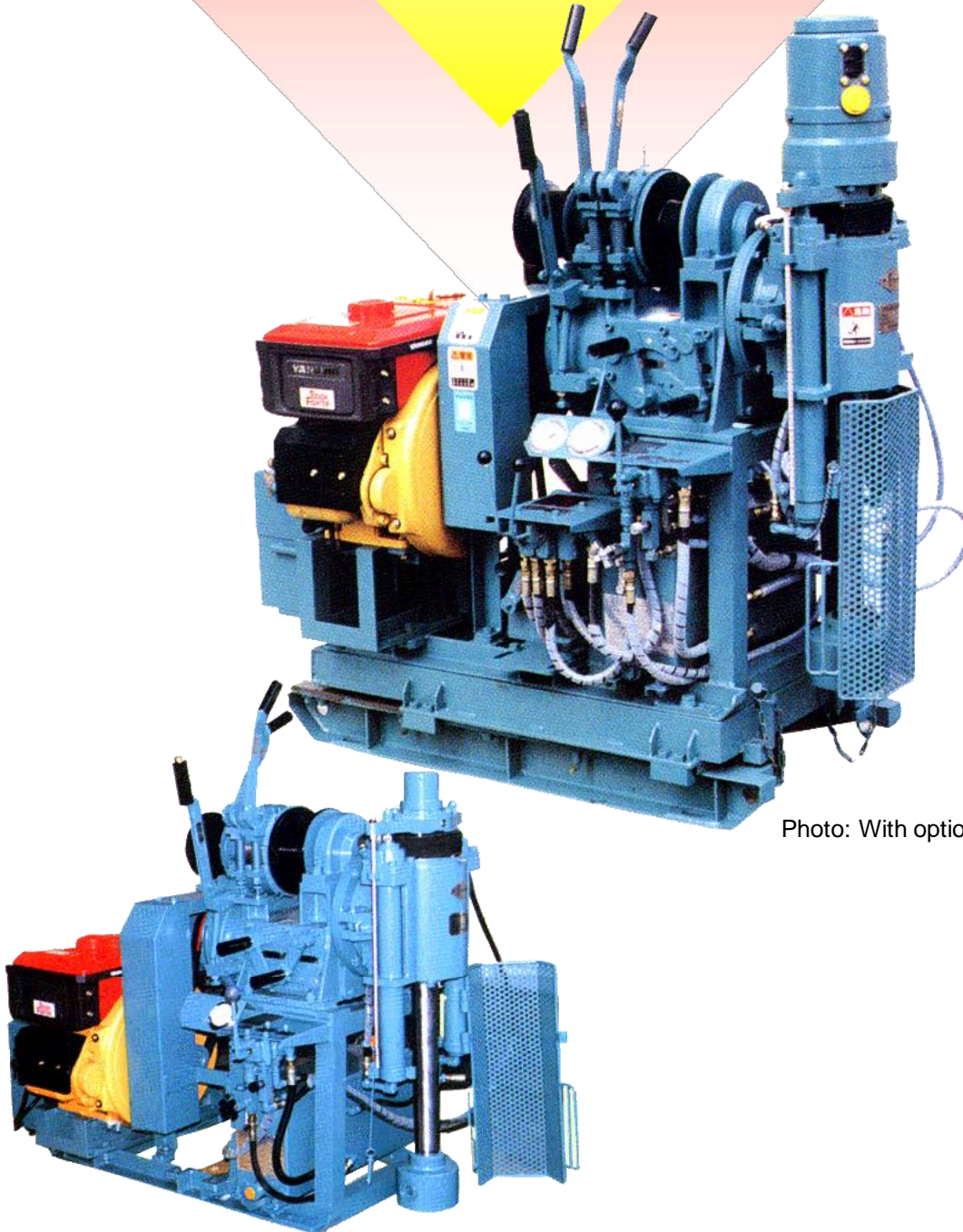

Photo: With options

With wide applications such as test boring, shallow mineral exploration from surface and underground, grout holes, soil sampling and site investigation



TOA-TONE BORING CO., LTD.

<http://www.toa-tone.jp>

Model TS-100 Drilling Machine

FEATURES

- ① Its compactness and light weight enable easier installation and mobilization.
- ② Optional hydraulic chuck does away the tediousness and dangers of manual chucking and yet it makes easier to operate and save time for further drilling per shift.
- ③ Rugged mechanism assures long trouble-free operation.

SPECIFICATIONS

CAPACITY

100m with 40.5 drill rod

POWER UNIT

Electric motor 3.7 kW, 4P, 50/60Hz
 Diesel engine Water-cooled, single cylinder,
 4 cycle, 6.5 - 8PS

TRANSMISSION

Type Sliding gear
 No. of speed 3 forward
 Clutch Heavy duty, single dry disc

HOIST

Type Planetary gear with band brake
 Hoist capacity 700 kg
 Drum capacity 20 m with 9 mm wire rope
 Rope speed 11, 23, 44 m/min.

BIT SPEED

65, 135, 255 rpm or 120, 250, 480 rpm

MUD PUMP (OPTION)

Type Single cylinder piston
 Max. discharge 40 L/min.
 Max. pressure 1.47 MPA

SWIVEL HEAD

Type Twin hydraulic cylinder
 Spindle ID 43 mm
 Feed stroke 400 mm
 Angle range 360 degree
 Max. thrust 13.72 kN
 Max. balance 19.60 kN

HYDRAULIC PUMP

Type Variable volume, vane
 Volume 0 - 10 L/min
 Max. pressure 6.86 MPa

MOUNTING

Type Steel skid frame

OVERALL DIMENSIONS (with options)

Length 1,235mm
 Width 1,065mm
 Height 1,400mm

APPROX. WEIGHT(without power unit) 430kg

OPTION

Hydraulic slide base with 300 mm stroke
 Hydraulic chuck, mud pump

Name of Components

- ① Swivel head
- ② Manual chuck
- ③ NP-40 mud pump (option)
- ④ Hoist lever
- ⑤ Clutch lever
- ⑥ Oil tank
- ⑦ Hydraulic pump
- ⑧ Hydraulic chuck (option)
- ⑨ Cover
- ⑩ Slide base (option)
- ⑪ Power unit

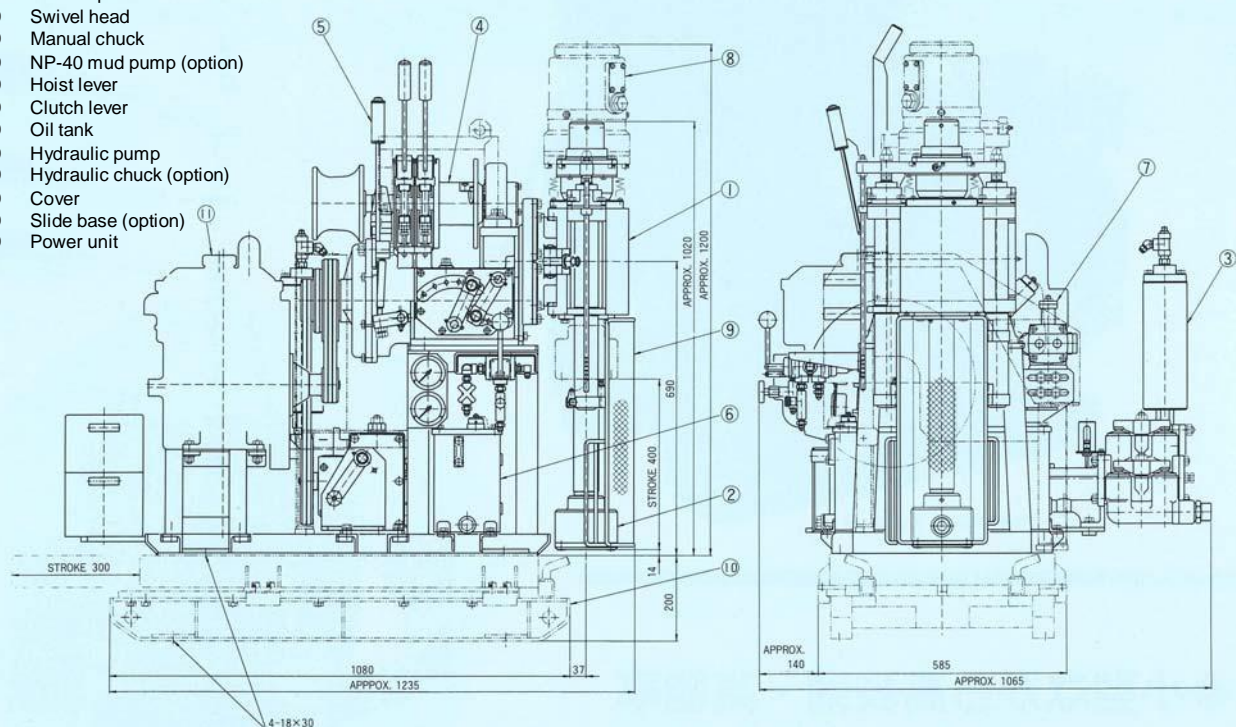

TOA-TONE BORING CO., LTD.

3-7 Roppongi 7-chome, Minato-ku, Tokyo 106-0032, Japan

Phone: 81-3-5775-3921 Fax: 81-3-5775-3967

ULR : <http://www.toa-tone.jp>

PT. Djawa Baru

Jl. Prof. Dr. Soepomo, SH, 45F Jakarta 12810, Indonesia

Phone : +62-21-829-8401 Fax : +62-21-829-8373

HP : +62-852-1679-9191 Email : support@djawabaru.co.id